

Datasheet

Si-113 EN

Ball segment valve

Edition: 2019-08

Type KVTW-A/KVXW-A

Wafer design Standard face to face dimension

Nominal pressure

PN 40/25/16/10, Class 300/150

PN 25/16/10, Class 150

Nominal size

DN 25/2 - 65

DN 80 - 250

- **Control and shut-off valve**
- **High capacity**
- **One-piece shaft gives torque transmission free of backlash**
- **Excellent tightness irrespective of differential pressure**
- **Easy maintenance**

The SOMAS ball segment valve type KVTW with a centrally mounted shaft, and KVXW with an eccentrically mounted shaft are of wafer design. The valve called the A-version is manufactured in standard face to face dimensions common in certain markets.

The valve is also manufactured in D-type version with a short face to face dimension. (See Si-114).

The valve body is in one piece. SOMAS unique shaft device is designed for torque transmission and gives backlash-free operation with accurate control. The spring-loaded seat is available in three alternative materials (PTFE, PTFE 53 and HiCo [High Cobalt Alloy]).

The valves can be used for control, as well as for shut-off applications on practically every type of media within a wide temperature range.

Choose KVTW for liquids, media containing impurities etc. For dry and clean media choose KVXW. In the KVXW-valve the ball segment is eccentrically mounted and rotates out from the seat when the valve is opened. This reduces the wear on seat and segment.

Low noise trim is available as an option on DN50 to DN250. The designation "LN" indicates that the ball segment is equipped with a network of bars that are used to split up the pressure drop across the valve. This results in less pressure recovery, thereby reducing the noise and potential damage due to cavitation.

Note! Capacity factors will be reduced for valves with LN-trim.

Ball segment DN50 to DN250 with V-groove is available for use at high fiber concentrations. The V-groove design prevents dewatering at small opening angles.

The SOMAS valves are delivered ready for installation and operation. The valve assemblies are delivered factory tested as complete units with actuators, positioners and accessories.



V-port MC



Low noise





Tightness class

The tightness class is related to the chosen material in the seat ring.

Control valves	On/Off valves
(EN 60534-4)	(EN 12266-1)
PTFE - Cl.V/Opt. Cl.VI	PTFE - Rate D/Opt. Rate C
PTFE 53/Peek - Cl.V	PTFE 53 - Rate D
HiCo - Cl.IV-S1/Opt. Cl.V	HiCo - Rate F/Opt. Rate E

Flow characteristics

100% Flow

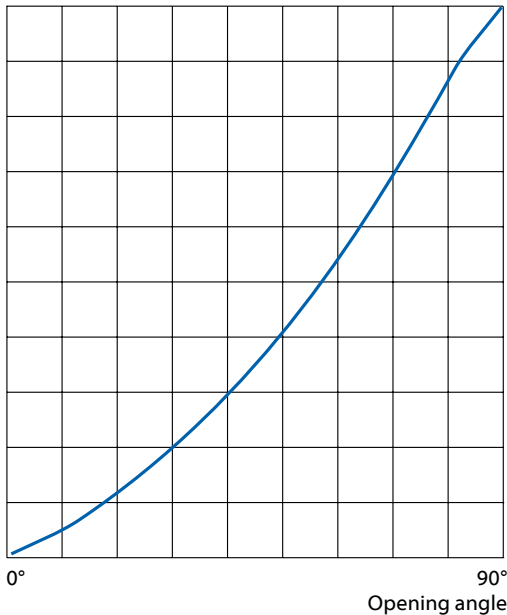

Factor FLP

	Opening angle								
	10°	20°	30°	40°	50°	60°	70°	80°	90°
FLP1	0.85	0.82	0.78	0.75	0.70	0.66	0.60	0.55	0.50
FLP2	0.85	0.82	0.78	0.73	0.68	0.62	0.56	0.50	0.45
FLP3	0.85	0.82	0.78	0.73	0.67	0.61	0.54	0.49	0.43

FLP1 = One dimension bigger pipe size
 FLP2 = Two dimensions bigger pipe size
 FLP3 = Three dimensions bigger pipe size

Liquid pressure recovery factor FL

Factor	Opening angle								
	10°	20°	30°	40°	50°	60°	70°	80°	90°
FL	0.85	0.82	0.80	0.77	0.74	0.71	0.67	0.64	0.60

Pipe geometry factor Fp

Valve DN	Pipe DN	Opening angle								
		10°	20°	30°	40°	50°	60°	70°	80°	90°
25	32				0.98	0.96	0.93	0.90	0.85	0.81
	40	1.0	0.99	0.98	0.95	0.91	0.85	0.79	0.71	0.66
	50				0.92	0.87	0.80	0.73	0.64	0.59
40	50				0.98	0.97	0.94	0.91	0.87	0.83
	65	1.0	0.99	0.98	0.95	0.91	0.85	0.79	0.71	0.66
	80				0.92	0.87	0.80	0.73	0.64	0.59
50	65				0.98	0.96	0.93	0.89	0.86	0.84
	80	1.0	0.99	0.98	0.95	0.91	0.85	0.79	0.71	0.66
	100				0.92	0.87	0.80	0.73	0.64	0.59
65	80				0.99	0.98	0.97	0.96	0.93	0.91
	100	1.0	0.99	0.98	0.95	0.91	0.85	0.79	0.73	0.64
	125				0.92	0.87	0.80	0.73	0.64	0.59

Pressure and temperature rating

According to seat material and body material.

Seat material Code	Max working temperature									
	150°C 300°F		170°C 340°F		200°C 400°F		350°C 660°F		>350°C >660°F	
PN50	A (PTFE)	36.3 bar	526 psi	35.3 bar	512 psi	-	-	-	-	-
	B (PTFE53)	36.3 bar	526 psi	35.3 bar	512 psi	20.15 bar	292 psi	-	-	Consult SOMAS
	T (HiCo)	36.3 bar	526 psi	35.3 bar	512 psi	33.7 bar	489 psi	17.03 bar	247 psi	
PN25	A (PTFE)	22.7 bar	329 psi	22 bar	319 psi	-	-	-	-	-
	B (PTFE53)	22.7 bar	329 psi	22 bar	319 psi	12.6 bar	183 psi	-	-	Consult SOMAS
	T (HiCo)	22.7 bar	329 psi	22 bar	319 psi	21 bar	305 psi	10.65 bar	155 psi	

Minimum working temperature -60°.
 If lower temperatures are needed contact SOMAS.



Capacity factor K_v and Resistance factor ζ for ball segment valve type KVTW/KVXW

Metric

DN	Opening angle									
	10°	20°	30°	40°	50°	60°	70°	80°	90°	ζ 90°
25/2	0.010	0.025	0.040	0.055	0.070	0.085	0.10	0.12	0.14	-
25/3	0.025	0.055	0.095	0.13	0.17	0.22	0.27	0.33	0.40	-
25/5	0.050	0.15	0.28	0.40	0.52	0.65	0.78	0.90	1.0	-
25/7	0.30	0.55	0.85	1.1	1.3	1.5	1.6	1.7	1.8	-
25/10	0.60	1.1	1.5	1.9	2.3	2.9	3.4	3.8	4.0	-
25/15	0.21	0.90	1.8	2.8	3.8	5.7	8.1	9.9	-	-
25/20	0.21	0.95	2	4.3	6.8	9.5	13.9	20	-	-
25	1.7	4.3	7.5	11.3	15.4	20.4	25.7	32.8	38	0.57
40/32	1	3.3	6.9	12.9	19	25	35	48	-	-
40	4.3	11	19	29	39	53	66	84	96	0.44
50	6.8	17	30	45	61	82	103	131	150	0.44
65	9.8	25	43	65	87	113	139	171	191	0.77
80	15	39	67	102	138	184	231	295	340	0.57
100	23	58	101	154	208	276	348	444	510	0.62
150	43	109	189	288	390	519	652	817	925	0.44
200	66	167	288	439	594	790	994	1268	1450	0.45
250	97	245	425	646	875	1162	1463	1866	2150	0.44

Capacity factor C_v and Resistance factor ζ for ball segment valve type KVTW/KVXW

US

NPS	Opening angle									
	10°	20°	30°	40°	50°	60°	70°	80°	90°	ζ 90°
1/0.079	0.012	0.029	0.047	0.064	0.081	0.099	0.12	0.14	0.16	-
1/0.12	0.029	0.064	0.11	0.15	0.20	0.26	0.31	0.38	0.47	-
1/0.2	0.058	0.17	0.33	0.47	0.60	0.76	0.91	1.0	1.2	-
1/0.28	0.35	0.64	0.99	1.3	1.5	1.7	1.9	2.0	2.1	-
1/0.4	0.70	1.3	1.7	2.2	2.7	3.4	3.9	4.4	4.7	-
1/0.6	0.24	1.0	2.1	3.3	4.4	6.6	9.4	11.5	-	-
1/0.8	0.24	1.1	2.3	5.0	7.9	11.0	16.2	23.3	-	-
1	2.0	5.0	8.7	13.1	17.9	23.7	29.9	38.1	44.2	0.57
1.5/1.25	1.2	3.8	8.0	15.0	22.1	29.1	40.7	55.8	-	-
1.5	5.0	12.8	22.1	33.7	45.3	61.6	76.7	97.7	112	0.44
2	7.9	19.8	34.9	52.3	70.9	95.3	120	152	174	0.44
2.5	11.4	29.1	50.0	75.6	101	131	162	199	222	0.77
3	17.4	45.3	77.9	119	160	214	269	343	395	0.57
4	26.7	67.4	117	179	242	321	405	516	593	0.62
6	50.0	127	220	335	453	603	758	950	1076	0.44
8	76.7	194	335	510	691	919	1156	1474	1686	0.45
10	113	285	494	751	1017	1351	1701	2170	2500	0.44



Metric
Ball segment valve type KVTW -A (standard)

DN	A (mm)	A1 (mm)	B (mm)	C (mm)	Ød (mm)	ØD (mm)	E (mm)	ØG (mm)	H (mm)	I (mm)	K (mm)	L (mm)	HCD (mm)	M (mm)	MM (mm)	O (mm)	P (mm)	R (mm)	S (mm)	V (mm)	X (mm)	Weight (kg)
25	60	31	47	83	25	65	62	15	75	3	35	17	60	M6	-	50	28	0	5	0	25	2.3
40	85	35	63	106	37	85	64	15	95	3	35	17	80	M8	-	50	28	0	5	0	25	4.4
50	95	43	72	106	50	102	64	15	105	3	35	17	80	M8	-	50	28	0	5	0	25	5.6
65	120	56	90	115	60	122	115	20	127	5	45	22.5	-	M12	-	61	42	98	6	48	30	8.5
80	111	64	102	115	75	140	115	20	127	5	45	22.5	-	M12	-	61	42	98	6	48	30	8.5
100	125	73	116	140	92	162	115	20	127	5	45	22.5	-	M12	-	61	42	98	6	48	30	11.5
150	170	101	151	176	124	216	115	25	127	5	45	28	-	M12	-	64	47	98	8	50	30	24
200	215	124	187	202	156	270	135	30	154	5	60	33	-	M12	24	72	50	123	8	62	40	44
250	260	150	230	242	189	324	135	35	154	5	50	38	-	M12	24	75	55	123	10	70	40	71

US
Ball segment valve type KVTW-A (standard)

Size	A (in)	A1 (in)	B (in)	C (in)	Ød (in)	ØD (in)	E (in)	ØG (in)	H (in)	I (in)	K (in)	L (in)	HCD (in)	M (in)	MM (in)	O (in)	P (in)	R (in)	S (in)	V (in)	X (in)	Weight (lbs)
1	2.36	1.22	1.85	3.27	0.98	2.56	2.44	0.59	2.95	0.12	1.38	0.67	2.36	M6	-	1.97	1.10	0.00	0.20	0.00	0.98	5.07
1.5	3.35	1.38	2.48	4.17	1.46	3.35	2.52	0.59	3.74	0.12	1.38	0.67	3.15	M8	-	1.97	1.10	0.00	0.20	0.00	0.98	9.7
2	3.74	1.69	2.84	4.17	1.97	4.02	2.52	0.59	4.13	0.12	1.38	0.67	3.15	M8	-	1.97	1.10	0.00	0.20	0.00	0.98	12.35
2.5	4.72	2.20	3.54	4.53	2.36	4.80	4.53	0.79	5.00	0.20	1.77	0.89	-	M12	-	2.40	1.65	3.89	0.24	1.89	1.18	18.74
3	4.37	2.52	4.02	4.53	2.95	5.51	4.53	0.79	5.00	0.20	1.77	0.89	-	M12	-	2.40	1.65	3.86	0.24	1.89	1.18	18.74
4	4.92	2.87	4.57	5.51	3.62	6.38	4.53	0.79	5.00	0.20	1.77	0.89	-	M12	-	2.40	1.65	3.86	0.24	1.89	1.18	25.35
6	6.69	3.98	5.95	6.93	4.88	8.50	4.53	0.98	5.00	0.20	1.77	1.10	-	M12	-	2.52	1.85	3.86	0.32	1.97	1.18	52.91
8	8.47	4.88	7.36	7.95	6.18	10.63	5.31	1.18	6.06	0.20	2.36	1.30	-	M12	0.94	2.84	1.97	4.84	0.32	2.44	1.58	97.00
10	10.24	5.91	9.06	9.53	7.48	12.76	5.31	1.38	6.06	0.20	1.97	1.50	-	M12	0.94	2.95	2.17	4.84	0.39	2.76	1.58	156.53

Wafer design

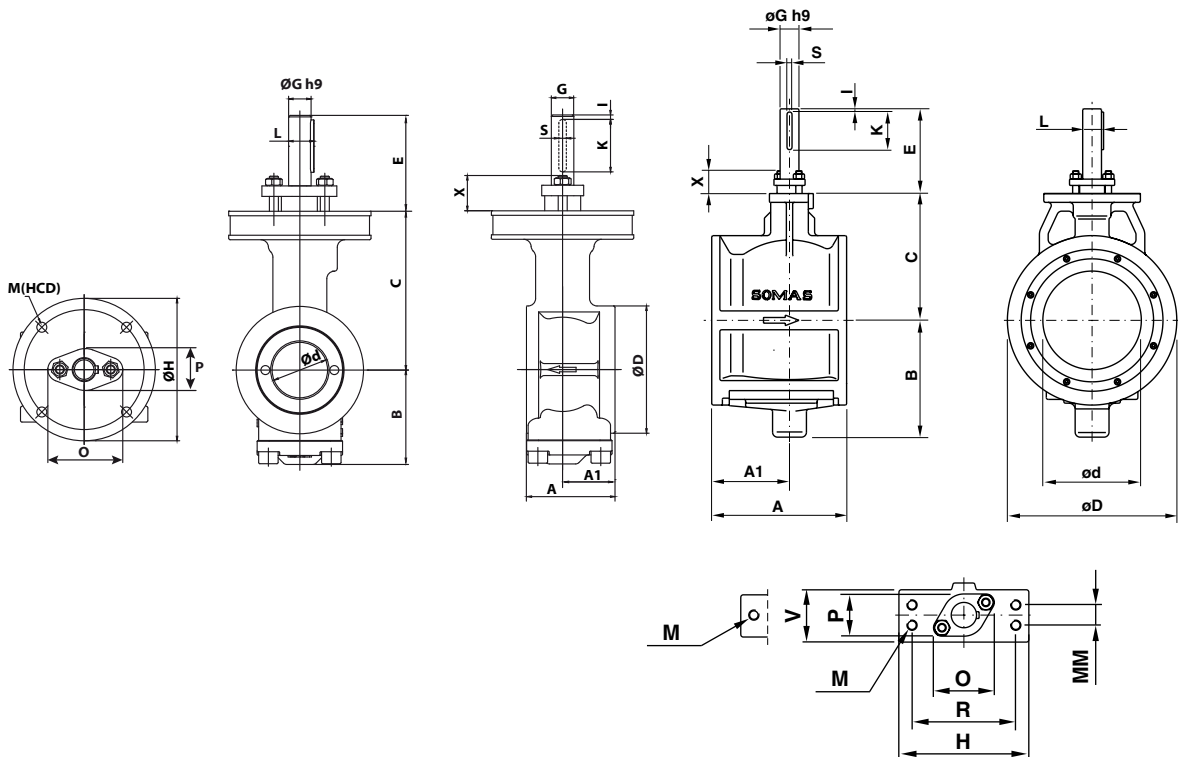

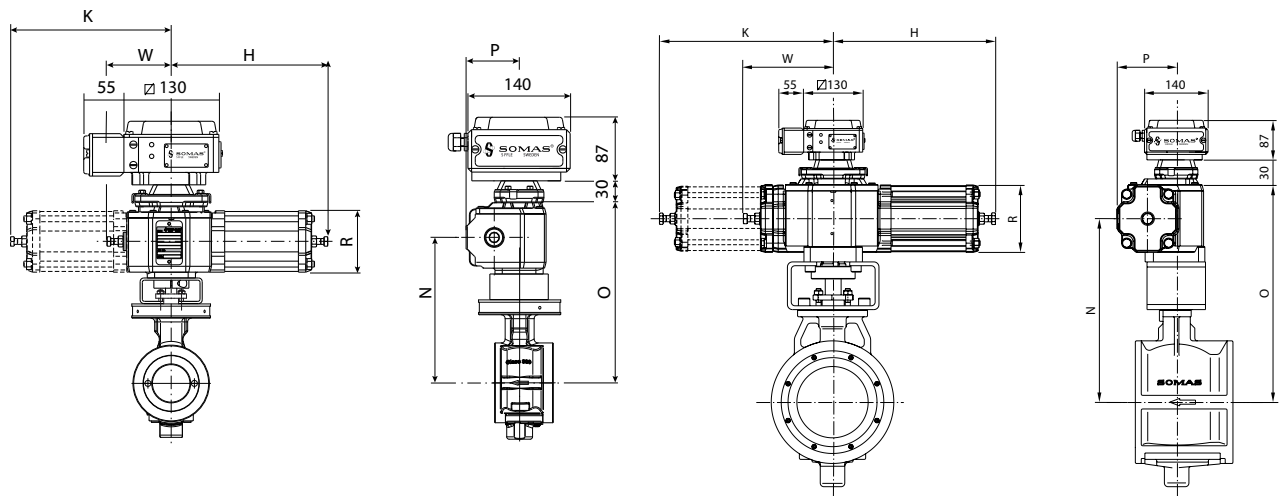

Ball segment valve type KVTW/KVXW with actuator type A-DA

DN	Type	H	K	N	O	P	R	W	Weight
25	A11	215	-	170	215	73	84	90	7
40	A11	215	-	190	240	73	84	90	9
50	A13	250	-	200	250	83	106	90	12
65	A21	255	-	280	345	94	106	140	18
65	A22	255	260	280	345	94	106	-	20
80	A21	255	-	260	340	94	106	140	18
80	A22	255	260	260	320	94	106	-	20
100	A21	255	-	285	345	94	106	140	21
100	A22	255	260	285	3,45	94	106	-	23
150	A22	255	260	320	385	94	106	-	35
150	A23	305	-	320	385	117	152	140	33
200	A24	305	310	345	410	117	152	-	61
200	A31	380	-	400	485	144	152	215	69
250	A31	380	-	440	525	144	152	215	96
250	A32	380	395	440	525	144	152	-	102

For units with the positioner type SP405, add 2 kg

For units with the positioner type SPE405, add 3 kg

Sizes and measurements in millimeters (mm).

Weights in kilograms (kg).

Ball segment valve type KVTW/KVXW with actuator type A-SC/SO

DN	Type	H	K	N	O	P	R	W	Weight
25	A13-X	325	-	170	215	83	106	90	11
40	A13-X	325	-	190	240	83	106	90	13
50	A13-X	325	-	201	250	83	106	90	14
50	A23-X	415	-	240	305	117	152	140	22
65	A23-X	415	-	280	345	117	152	140	26
80	A23-X	415	-	260	320	117	152	140	26
100	A23-X	415	-	285	345	117	152	140	29
150	A24-X	415	420	320	385	117	152	-	51
200	A33-X	660	-	400	485	183	228	215	102
250	A33-X	660	-	440	525	183	228	215	129

X = SC – Spring to close

X = SO – Spring to open

Sizes and measurements in millimeters (mm).

Weights in kilograms (kg).



Wafer design

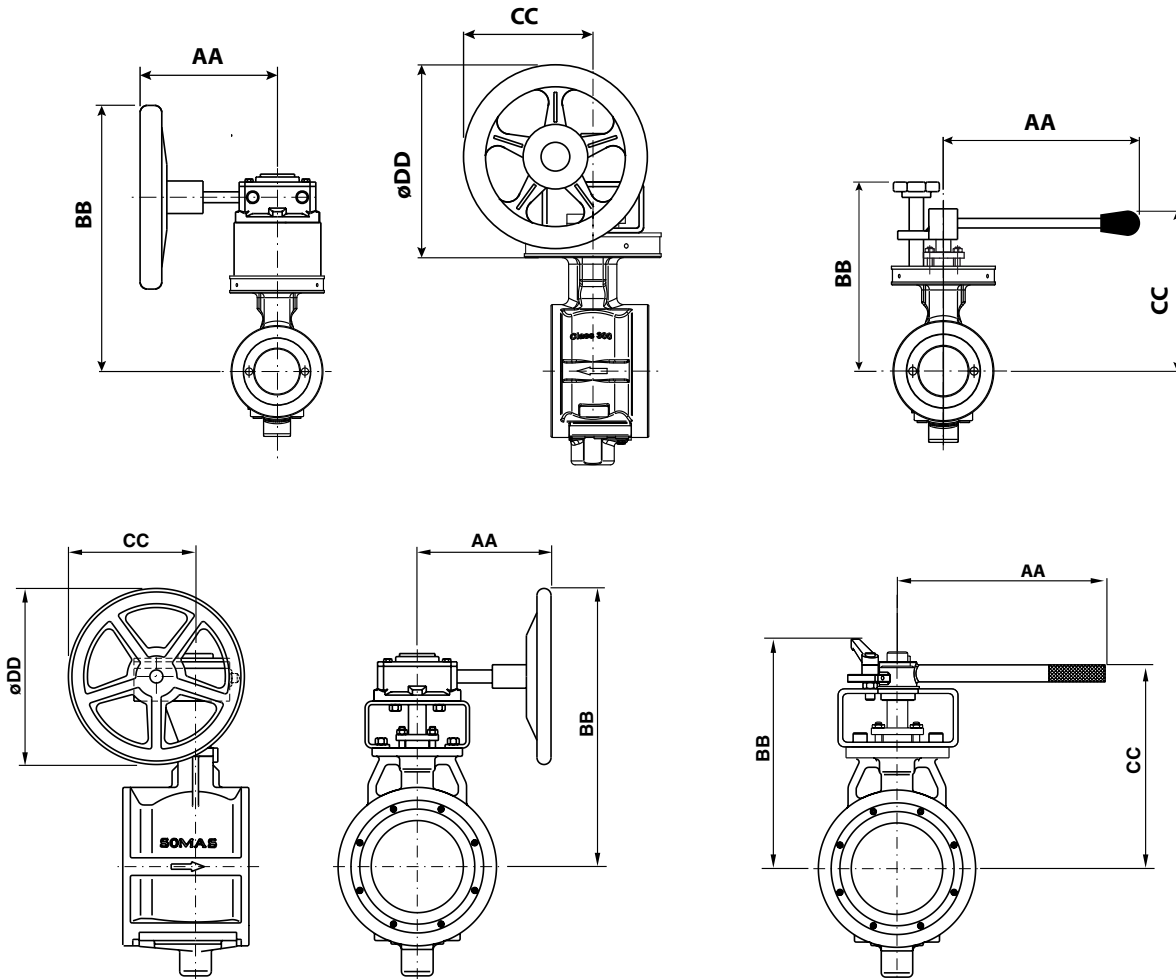

Ball segment valve type KVTW/KVXW with hand gear

DN	Type	AA	BB	CC	ØDD	Weight
25	M7/F05	155	200	105	125	6
40	M7/F05	155	225	105	125	9
50	M7/F05	155	240	105	125	11
65	M10/F07	190	370	180	255	22
80	M10/F07	190	350	190	255	16
100	M10/F07	190	380	190	255	19
150	M10/F07	190	410	190	255	32
200	M12/F12	228	475	230	305	56
250	M12/F12	228	515	230	305	83

Ball segment valve type KVTW/KVXW with hand lever

DN	Type	AA	BB	CC	Weight
25	HK115	195	175	145	3
40	HK125	195	200	170	6
50	HK125	195	210	180	8
65	HSR20	350	305	245	16
80	HSR20	355	240	210	11.5
100	HSR20	355	265	235	14.5
150	HSR25	355	301	271	27



Actuator selection table air supply 5.5 bar

Valve DN	Shaft (mm) dia.	Closing torque (Nm)			Double acting 5,5 (bar) supply air		Condition $\Delta p \leq 10(\text{bar})$	Single acting 5,5 (bar) supply air		Condition $\Delta p \leq 10(\text{bar})$
		$\Delta p > 10(\text{bar})$	$\Delta p \leq 10(\text{bar})$	Max allowable	$\Delta p > 10(\text{bar})$	$\Delta p \leq 10(\text{bar})$		$\Delta p > 10(\text{bar})$	$\Delta p \leq 10(\text{bar})$	
25/15-25	15	25	23	80	A11-DA	A11-DA		A13-SC/SO	A13-SC/SO	
40/32-40	15	45	41	80	A11-DA	A11-DA		A13-SC/SO	A13-SC/SO	
50	15	55	50	80	A13-DA	A11-DA		A13-SC/SO	A13-SC/SO	
65	20	120	110	200	A21-DA	A13-DA		A23-SC/SO	A23-SC/SO	
80	20	120	110	200	A21-DA	A13-DA		A23-SC/SO	A23-SC/SO	
100	20	150	120	200	A21-DA	A13-DA	No HiCo	A23-SC/SO	A23-SC/SO	
150	25	250	185	370	A22-DA	A21-DA	No HiCo	A24-SC/SO	A24-SC/SO	
200	30	400	295	640	A31-DA	A22-DA		A33-SC/SO	A24-SC/SO	No HiCo
250	35	600	449	1000	A31-DA	A31-DA		A33-SC/SO	A33-SC/SO	

No HiCo = "No HiCo seats" Valves with HiCo seats should not use PN10 actuators. PTFE/PTFE53 is OK

Actuator selection table air supply 4 bar

Valve DN	Shaft (mm) dia.	Closing torque (Nm)			Double acting 4,0 (bar) supply air		Condition $\Delta p \leq 10(\text{bar})$	Single acting 4,0 (bar) supply air		Condition $\Delta p \leq 10(\text{bar})$
		$\Delta p > 10(\text{bar})$	$\Delta p \leq 10(\text{bar})$	Max allowable	$\Delta p > 10(\text{bar})$	$\Delta p \leq 10(\text{bar})$		$\Delta p > 10(\text{bar})$	$\Delta p \leq 10(\text{bar})$	
25/15-25	15	25	23	80	A11-DA	A11-DA		A13-SCL/SOL	A13-SCL/SOL	
40/32-40	15	45	41	80	A11-DA	A11-DA		A13-SCL/SOL	A13-SCL/SOL	
50	15	55	50	80	A13-DA	A11-DA		A23-SC/SOL	A23-SCL/SOL	
65	20	120	110	200	A22-DA	A21-DA		A23-SC/SOL	A23-SCL/SOL	
80	20	120	110	200	A22-DA	A21-DA		A23-SC/SOL	A23-SCL/SOL	
100	20	150	120	200	A22-DA	A21-DA	No HiCo	A23-SC/SOL	A23-SCL/SOL	
150	25	250	185	370	A23-DA	A22-DA		A24-SC/SOL	A24-SCL/SOL	
200	30	400	295	640	A24-DA	A23-DA	No HiCo	A33-SC/SOL	A24-SCL/SOL	No HiCo
250	35	600	449	1000	A32-DA	A31-DA	No HiCo	A33-SC/SOL	A33-SCL/SOL	

No HiCo = "No HiCo seats" Valves with HiCo seats should not use PN10 actuators. PTFE/PTFE53 is OK

SC/SCL = Spring to close at air failure

SO/SOL = Spring to open at air failure

Face to face dimension

According to Industrial branch standards, standard face to face dimension.

Flange standard

SOMAS ball segment valves type KVTW DN 80–250 and KVXW with nominal size DN25–250 are flangeless and should be clamped between flanges.

When ordering, please always state the pressure rating of the counter flanges. See the valve specification system on page 8, code 13.

Further technical information

Technical data for the materials used in the SOMAS valves, flange standard, steam data, etc. can be found in documents library on www.somas.se.

Actuators and accessories

The valves can be fitted with SOMAS manual, on/off or control actuators in accordance with the selection table. The valves will then be delivered as tested units ready for installation.

In the documents library on www.somas.se there is also information about positioners, limit switches and solenoid valves.

We can also fit other types of actuators and accessories in accordance with your specification.



Option

Within the process industry and the energy sector there are a number of applications where process data in combination with standard control valves will end up with problems such as high noise level and erosion. These issues are mostly related to cavitations and high flow velocities inside the valve.

Note! By using a standard ball segment valve and add a noise reduction trim many of the above mentioned issues can be solved.

See data sheet Si-108 for more theoretical information.

For controlling suspensions with high fiber concentrations it can be advantageous to use valves with a V-groove to reduce the risk of de-watering at small opening angles.

Capacity factors and remaining factors for valves with LN-trim and valves with V-groove are available in the valve sizing program SOMSIZE.

Ordering

State desired valve according to the valve specification system below as well as type of actuator, positioner and accessories.

Valve sizing

Use SOMAS valve sizing program SOMSIZE to find the correct valve size. All sizing factors are included in the program.

Valve specification system

KVTW - A 5 - A J A - B 1 1 - DN... - D... - B... - PN...

1 2 3 4 5 6 7 8 9 10 11 12 13

1 Type of valve

KVTW (centrically mounted segment)
KVXW (excentrically mounted segment)
KVTW LN (centrically mounted segment, Low Noise)
KVXW LN (excentrically mounted segment, Low Noise)
KVMW (ball segment with V-groove)

2 Valve body design

A = Wafer style design according to branch standard.
Standard face to face length

3 Nominal pressure

5 = PN25
6 = PN40/Class 300

4 Material – valve body

A = CF8M (1.4408)

5 Material – segment

K = Hard chromed 1.4460
L = HiCo coated 1.4460
J = 1.4460

6 Material – seat

A = PTFE (10% carbon)
B = PTFE53 (50% PTFE + 50% 1.4435 powder)
T = HiCo (High Cobalt Alloy)

7 Material – shaft

B = 1.4460 (DN25-50)
/ SS 2324-12 (DN65-250) (Hard chromed)
A = 1.4460 (DN25-50)
/ SS 2324-12 (DN65-250)

8 Bearings – valve body/shaft

1 = Without bearing
7 = Stainless steel

9 Stuffing box

1 = Graphite
2 = PTFE

10 Valve size, DN

11 Shaft diameter

12 Actuator mounting flange drilling

13 Drilling, counter flanges, PN/Class

SOMAS reserves the right to make improvements without prior notice.



SOMAS[®]
www.somas.se

P.O. Box 107
SE-661 23 SÄFFLE
SWEDEN

Phone: +46 533 167 00
E-mail: sales@somas.se